

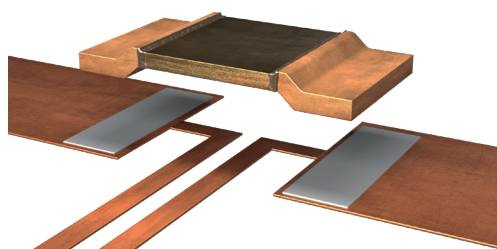

## ISA-WELD® // PRECISION RESISTORS



### BVS (3920)



#### Features

- Power rating up to 12 W<sup>1</sup>
- Continuous current load up to 245 A (0.2 mOhm)
- Heavy copper connectors
- Excellent long-term stability
- Max. solder temperature up to 350 °C / 30 sec
- AEC-Q200 qualified
- RoHS 2011/65/EU compliant



#### Applications

- Current sensor for power hybrid applications
- High current applications for the automotive market
- Frequency converters
- Power modules

#### Technical data <sup>1</sup>

Resistance values	<b>mOhm</b>	0.1 to 5
Tolerance	<b>%</b>	1 / 5
Temperature coefficient (20-60 °C)	<b>ppm/K</b>	from 0 ± 50
Applicable temperature range	<b>°C</b>	-65 to +170
Power rating <b>P<sub>70°C</sub></b>	<b>W</b>	up to 12
Internal heat resistance (R <sub>thi</sub> )	<b>K/W</b>	from 2
Inductance	<b>nH</b>	<3
Stability (at rated power) deviation after 2000h	<b>%</b>	<0.5 (T <sub>max.</sub> =140 °C) <1.0 (T <sub>max.</sub> =170 °C)

<sup>1</sup> For detailed information see table on page 3

#### Ordering code

BVS - M - R0005 - 1.0

.....	Tolerance
.....	Resistance value [Ohm] / „R” represents decimal point
.....	Material (MANGANIN®)
.....	Type



**Mechanical dimensions and pcb-layout proposal (Reflow-soldering) [mm]**

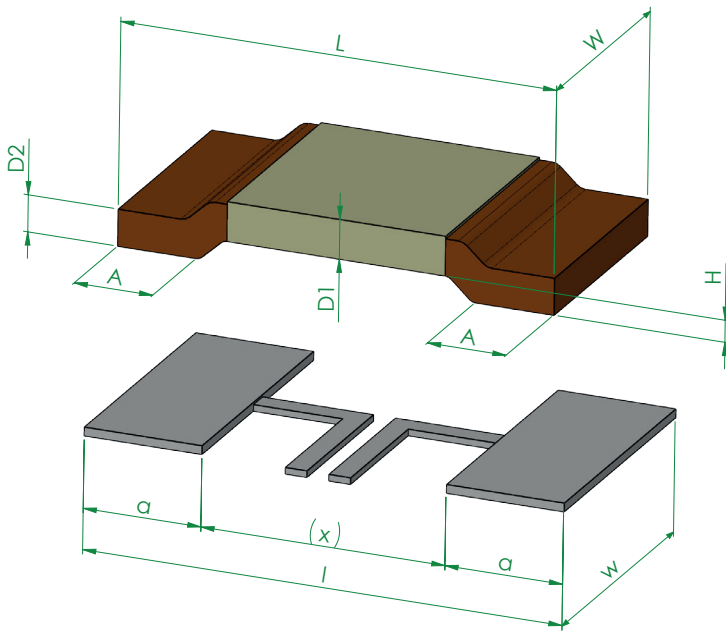

**Mechanical dimensions**

Type	Value [mΩ]	L	W	H	A	D1	D2
BVS-K-R000	<0.2	10 +0.3	5.2 +0.3/-0.2	0.5 ±0.1	2 -0.5	1 ±0.1	1 ±0.1
BVS-Z-R0001	0.1	10 +0.3	5.2 +0.3/-0.2	0.5 ±0.1	2.25 +0.3/-0.5	1.42 ±0.1	1.42 ±0.1
BVS-Z-R0002	0.2	10 +0.3	5.2 +0.3/-0.2	0.5 ±0.1	2 -0.5	1.49 ±0.1	1.42 ±0.1
BVS-M-R0003	0.3	10 +0.3	5.2 +0.3/-0.2	0.5 ±0.1	2 -0.5	1.42 ±0.1	1.42 ±0.1
BVS-M-R0005	0.5	10 +0.3	5.2 +0.3/-0.2	0.5 ±0.1	2 -0.5	0.84 ±0.1	0.84 ±0.1
BVS-M-R0007	0.7	10 +0.3	5.2 +0.3/-0.2	0.5 ±0.1	2 -0.5	0.6 ±0.1	0.64 ±0.1
BVS-M-R001	1	10 +0.3	5.2 +0.3/-0.2	0.5 ±0.1	2 -0.5	0.42 ±0.05	0.42 ±0.05
BVS-A-R001	1	10 +0.3	5.2 +0.3/-0.2	0.5 ±0.1	2 -0.5	1.32 ±0.1	1.30 ±0.1
BVS-I-R001	1	10 +0.3	5.2 +0.3/-0.2	0.5 ±0.1	2 -0.5	1.32 ±0.1	1.30 ±0.1
BVS-A-R0015	1.5	10 +0.3	5.2 +0.3/-0.2	0.5 ±0.1	2 -0.5	0.91 ±0.1	0.84 ±0.1
BVS-A-R002	2	10 +0.3	5.2 +0.3/-0.2	0.5 ±0.1	2 -0.5	0.64 ±0.1	0.64 ±0.1
BVS-I-R002	2	10 +0.3	5.2 +0.3/-0.2	0.5 ±0.1	2 -0.5	0.66 ±0.1	0.64 ±0.1
BVS-V-R002	2	10 +0.3	5.2 +0.3/-0.2	0.5 ±0.1	2 -0.5	0.44 ±0.1	0.42 ±0.1
BVS-A-R0028	2.8	10 +0.3	5.2 +0.3/-0.2	0.5 ±0.1	2 -0.5	0.44 ±0.05	0.64 ±0.1
BVS-A-R003	3	10 +0.3	5.2 +0.3/-0.2	0.5 ±0.1	2 -0.5	0.44 ±0.05	0.42 ±0.05
BVS-I-R003	3	10 +0.3	5.2 +0.3/-0.2	0.5 ±0.1	2 -0.5	0.44 ±0.05	0.42 ±0.05
BVS-A-R004	4	10 +0.3	5.2 +0.3/-0.2	0.5 ±0.1	2 -0.5	0.31 ±0.05	0.4 ±0.05
BVS-I-R004	4	10 +0.3	5.2 +0.3/-0.2	0.5 ±0.1	2 -0.5	0.36 ±0.05	0.4 ±0.1
BVS-I-R005	5	10 +0.3	5.2 +0.3/-0.2	0.5 ±0.1	2 -0.5	0.35 ±0.05	0.4 ±0.05

**Solder pad dimensions**

Type	l	w	a	x
BVS	11	6.2	2.7	5.6
BVS-Z-R0001	11	6.2	3.6	3.8



BVS // 3920

**Recommended solder profile**

Reflow-, IR-soldering

Temperature	°C	260	255	217
Time	sec	peak	40	90

**Alternative solder profile**

H2 soldering under vacuum

Temperature	°C	350
Time	min	20

**Tape and reel information**

Specification	DIN EN 60286-3		
Tape width	mm	16	
Reel size	inch	13	
Parts per reel	pcs	3000	
Packaging weight	g	474	

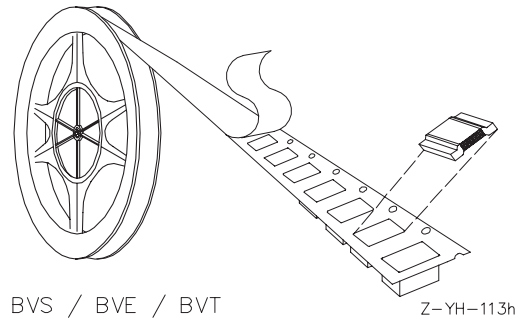

**Electrical specification**

Type	Material	Value [mΩ]	R <sub>thi</sub> [K/W]	TCR [ppm/K]	P <sub>70°C*</sub> [W]	P <sub>&gt;100°C*</sub> [W]	Note
BVS-Z-R0001	ZERANIN®30	0.1	2.0	300 ± 50	12	7	C-samples available, qualification in process
BVS-Z-R0002	ZERANIN®30	0.2	3	150 ± 50	12	5	
BVS-M-R0003	MANGANIN®	0.3	4.5	100 ± 50	10	5	
BVS-M-R0005	MANGANIN®	0.5	8	20 ± 50	9	5	
BVS-M-R0007	MANGANIN®	0.7	11	10 ± 50	8	5	
BVS-M-R001	MANGANIN®	1	15	0 ± 50	7	4	
BVS-A-R001	Aluchrom	1	9	0 ± 50	8	5	Aluchrom material has ferromagnetic properties and should not be used in AC-applications
BVS-A-R0015	Aluchrom	1.5	12	0 ± 50	7	4.5	
BVS-A-R002	Aluchrom	2	16	0 ± 50	6	4	
BVS-A-R0028	Aluchrom	2.8	21	0 ± 50	5	3	
BVS-A-R003	Aluchrom	3	22	0 ± 50	5	3	
BVS-A-R004	Aluchrom	4	30	0 ± 50	4	2.5	
BVS-I-R001	ISAOHM®	1	9	0 ± 50	8	5	
BVS-I-R002	ISAOHM®	2	16	0 ± 50	6	4	
BVS-I-R003	ISAOHM®	3	22	0 ± 50	5	3	
BVS-I-R004	ISAOHM®	4	30	0 ± 50	3.5	2.5	
BVS-I-R005	ISAOHM®	5	38	0 ± 50	2.5	2	
BVS-V-R002	NOVENTIN®	2	20	0 ± 50	5	3.5	
BVS-K-R000	SF-copper tinned	<0.2 mΩ			I <sub>max</sub> = 160 A		

\* Recommended max. power (limited by thermal conditions of the assembly)

**Note:** For calculation of the maximum derating terminal temperature (T<sub>K</sub>) the following formula can be used: T<sub>K</sub> = T<sub>max.</sub> - (R<sub>thi</sub> × P).

Example for BVS-M-R0005: T<sub>K</sub> = 170 °C - (8 K/W × 5 W) = 130 °C.



BVS // 3920

**Power derating curve at 70°C**

For detailed information see table "Electrical specification"

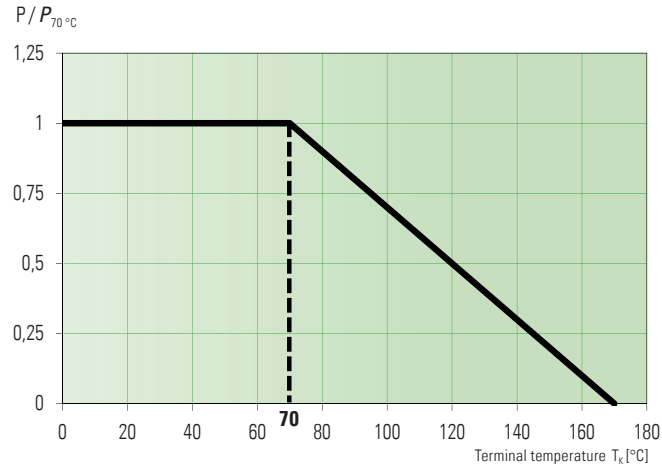

**Power derating curve BVS-Z-R0001 / BVS-Z-R0002**

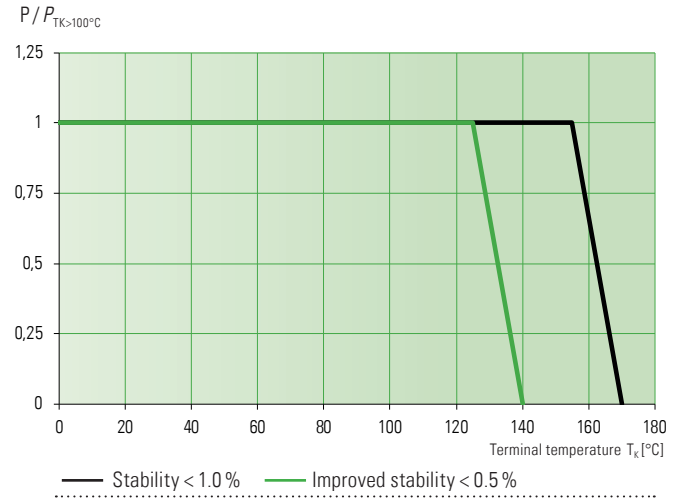

**Power derating curve BVS-M-R0003**

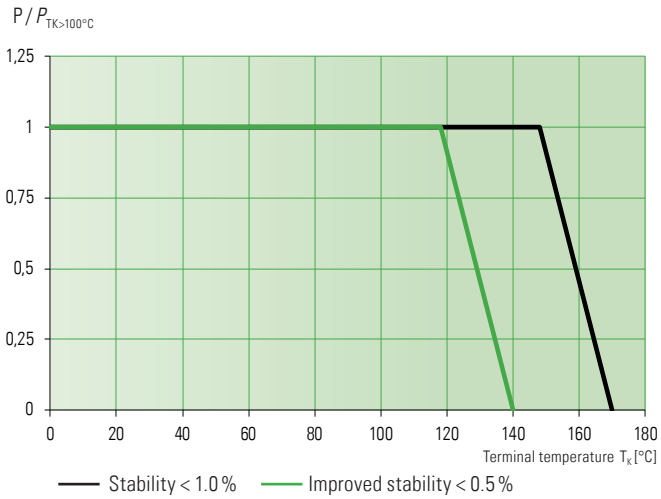

**Power derating curve BVS-M-R0005**

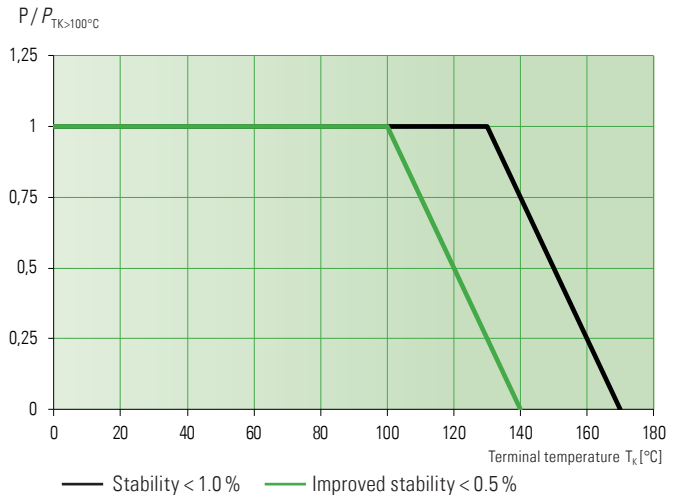

**Power derating curve BVS-M-R001**

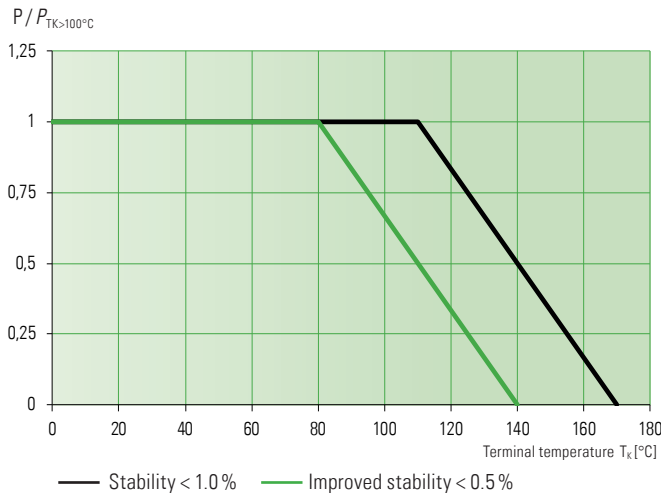

**Power derating curve BVS-M-R0007**

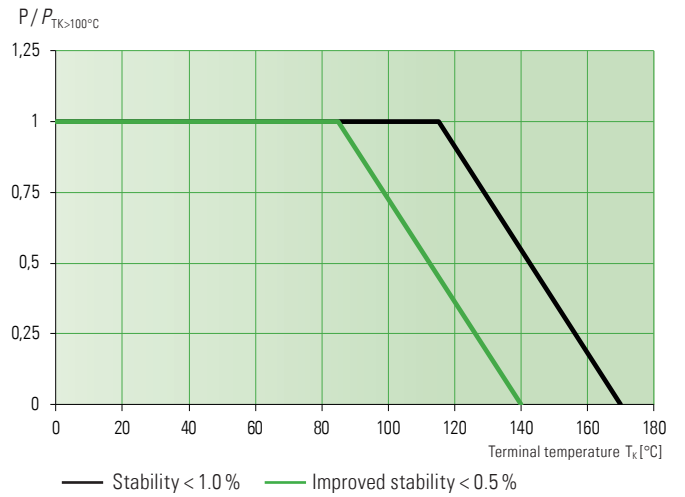



BVS // 3920

**Power derating curve BVS-I-R001**

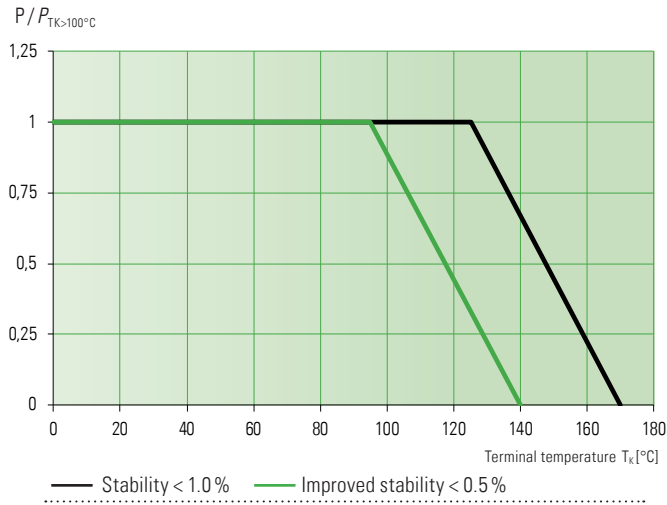

**Power derating curve BVS-I-R002 / BVS-I-R003**

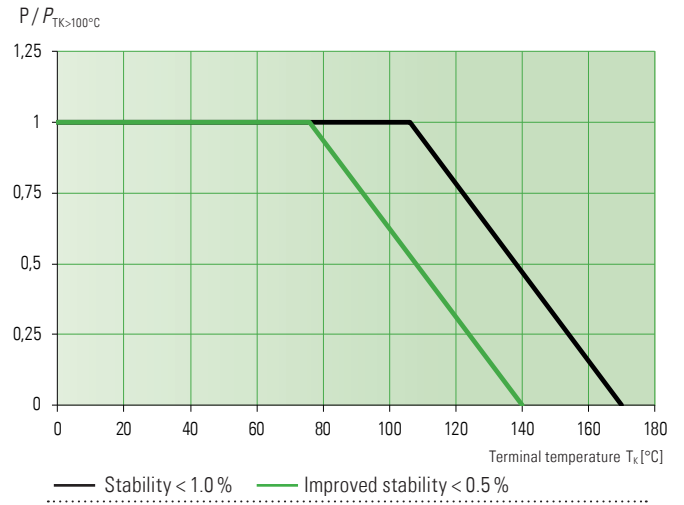

**Power derating curve BVS-V-R002 / BVS-I-R004**

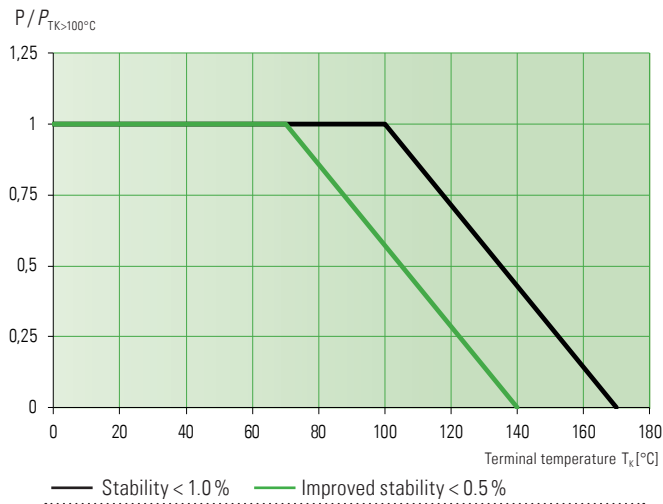

**Power derating curve BVS-I-R005**

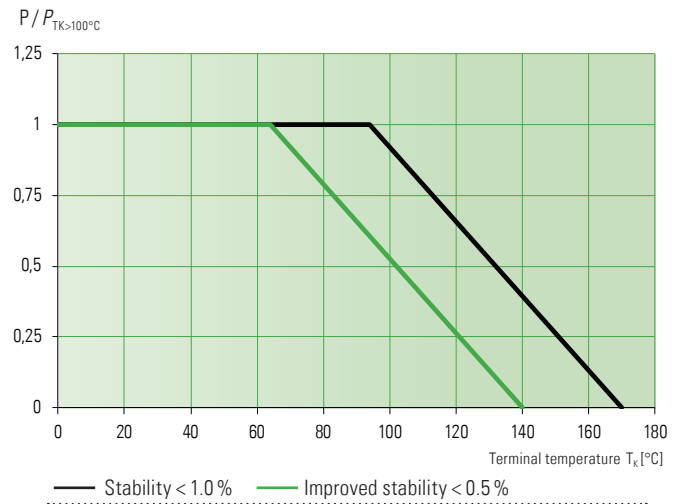

Further power derating curves on request.



BVS // 3920

**Temperature dependence of the electrical resistance of Aluchrom resistors**

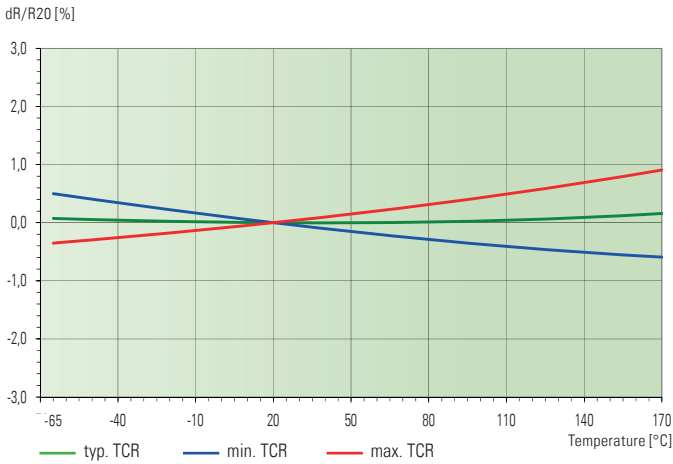

**Temperature dependence of the electrical resistance of ISAOHM® resistors**

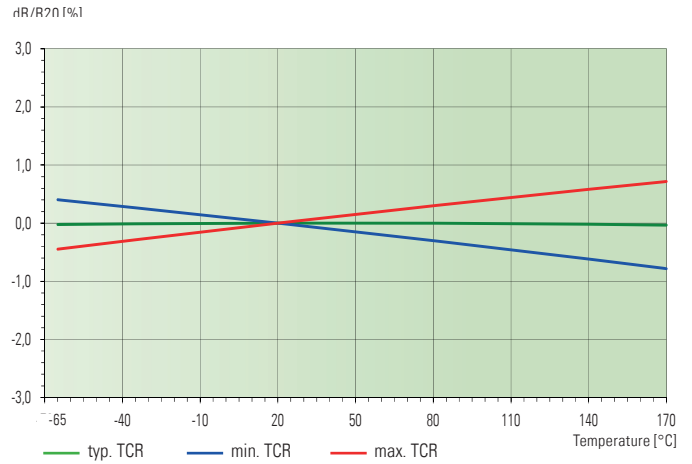

**Temperature dependence of the electrical resistance of MANGANIN® resistors. Example: BVS-M-R001**

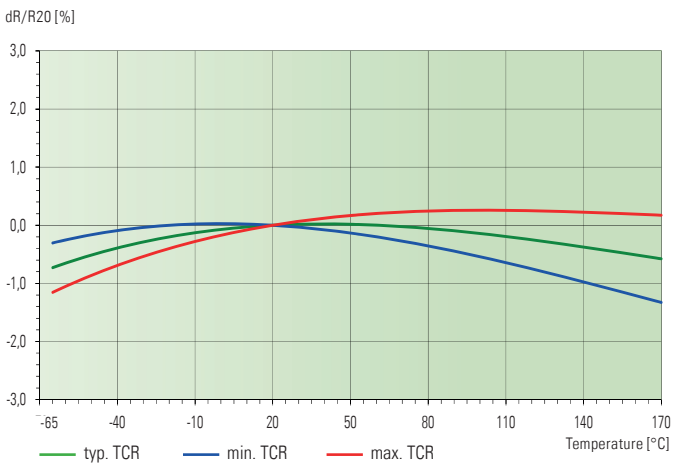

**Temperature dependence of the electrical resistance of NOVENTIN® resistors**

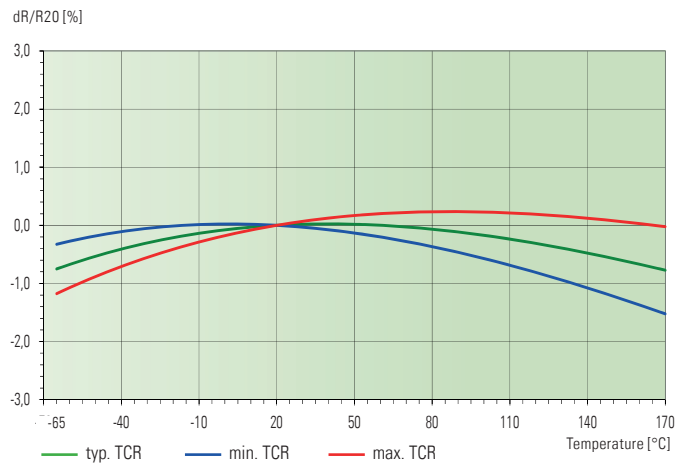

**Temperature dependence of the electrical resistance of ZERANIN® resistors. Example: BVS-Z-R0001**

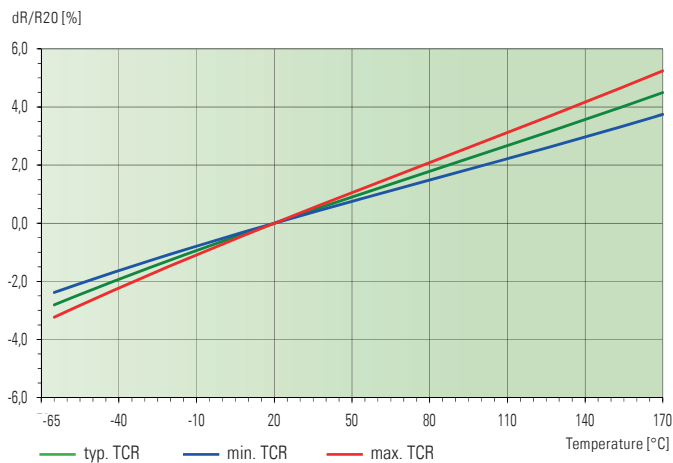



Maximum pulse energy respectively pulse power for permanent operation

**BVS-I-R005**                      **BVS-Z-R0001**                      **BVS-M-R001**  
 Maximum pulse energy / power for continuous operation ( $T_K = 70\text{ °C}$ )

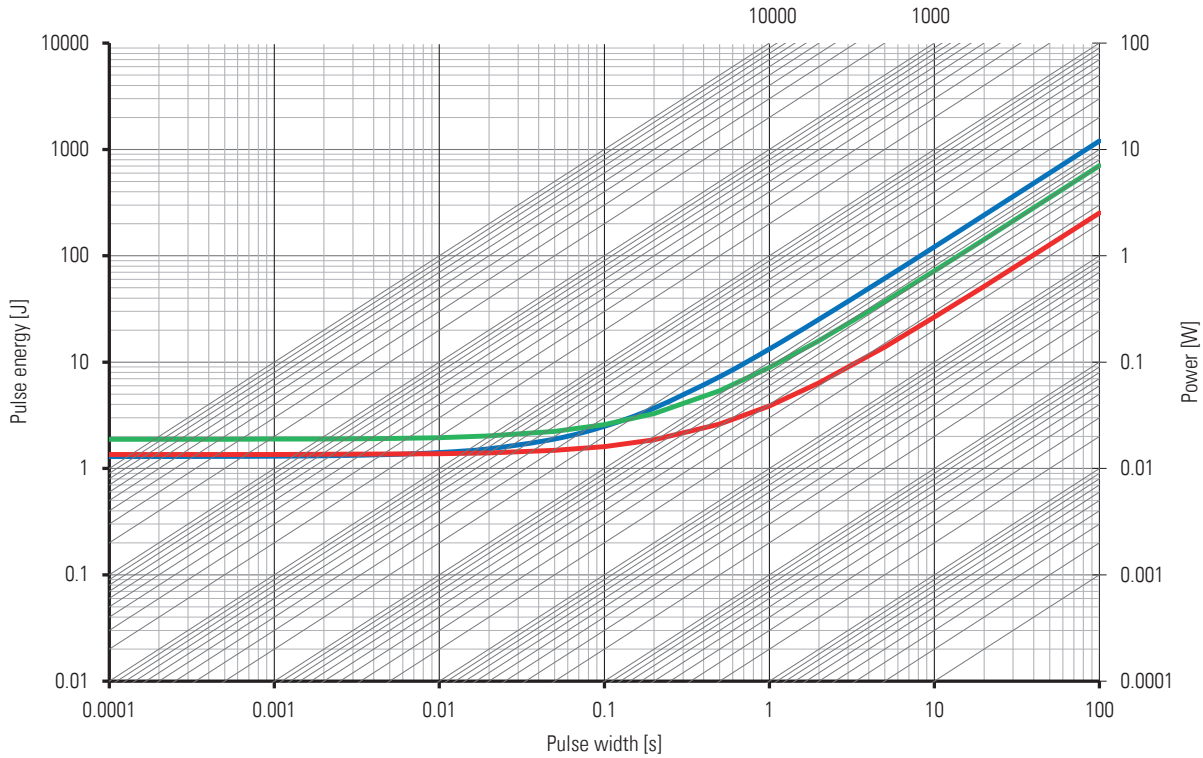

**Test specification**

Parameters	Test conditions	Specified values
Temperature Cycling	2000 cycles (-55 °C to +150 °C)	±0.5 %
Low Temperature Storage and Operation	-65 °C for 250 h	±0.1 %
Resistance to Soldering Heat	260 °C for 10 sec / 8h steam aging	n.a.
Moisture Resistance	MIL-STD-202 method 106	±0.1 %
Mechanical Shock	100 g, 6 ms half sine	±0.2 %
Vibration, High Frequency	10 g, 10-2000 Hz, 24 h each axis	±0.2 %
Operational Life	2000 h, max. $T_K$ at rated power	±1.0 %
High Temperature Exposure	2000 h / 170 °C (in covered condition)*	±1.0 %
Bias Humidity	+85 °C, 85 r.F., 1000 h	±0.5 %

\* for MANGANIN® and ZERANIN®30

**Disclaimer** // All products, product specifications and data are subject to change without notice. The product specifications do not expand or otherwise modify Isabellenhütte's terms and conditions of sale, including but not limited to, the warranty expressed therein. Isabellenhütte makes no warranty, representation or guarantee other than as set forth in its terms and conditions of sale. Information provided in datasheets and/or specifications may vary from actual results in different applications. Any statements made by Isabellenhütte regarding the suitability of products for certain types of applications are based on its knowledge of typical requirements that are often placed on its products. It is the customer's responsibility to validate that a particular product with the properties described in the product specification is suitable for use in the application intended. No license, express or implied, or otherwise, to any intellectual property rights is granted by this document. Any and all liability arising out of the application or use of any product shall be as set forth in Isabellenhütte's terms and conditions of sale.

