

Jan.1.2022 Copyright 2022 HIROSE ELECTRIC CO., LTD. All Rights Reserved.  
 In case of consideration for using Automotive equipment / device which demand high reliability, kindly contact our sales window correspondents.

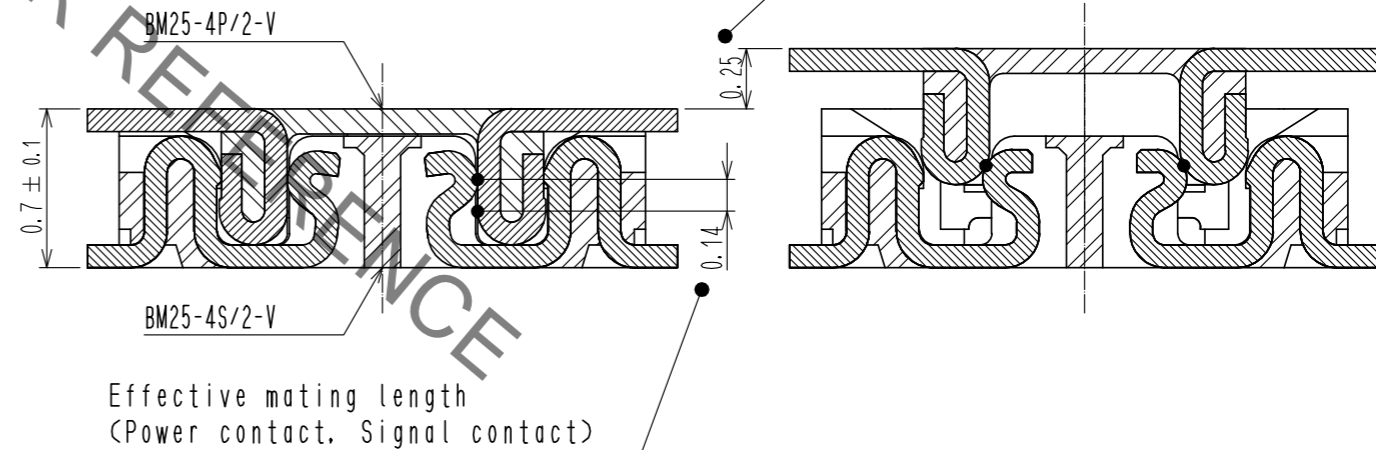
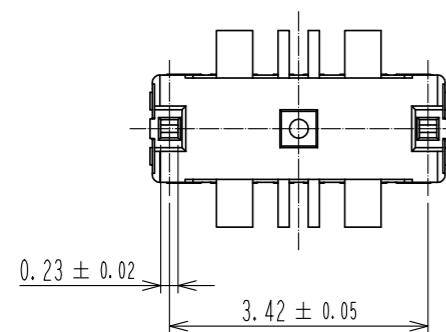
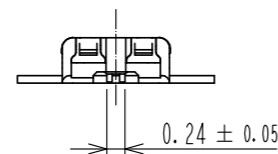
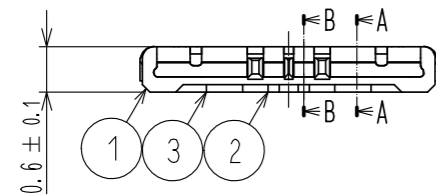
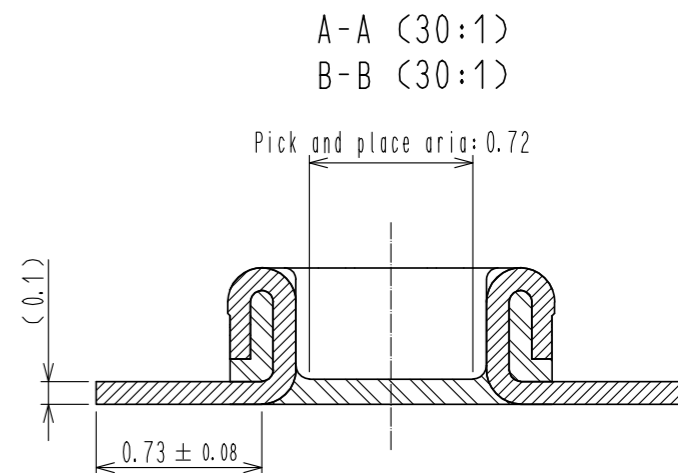
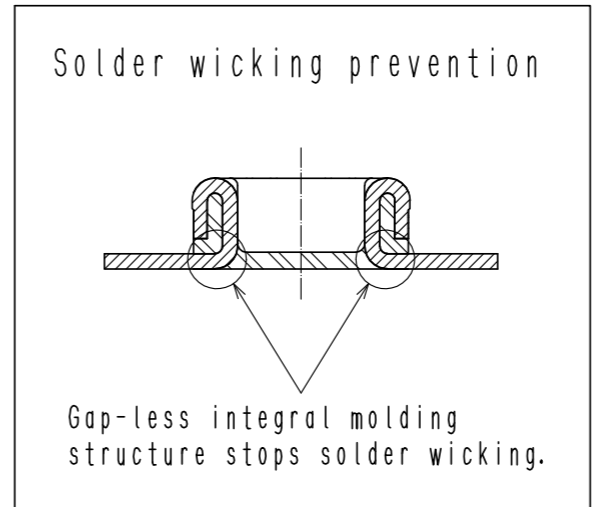
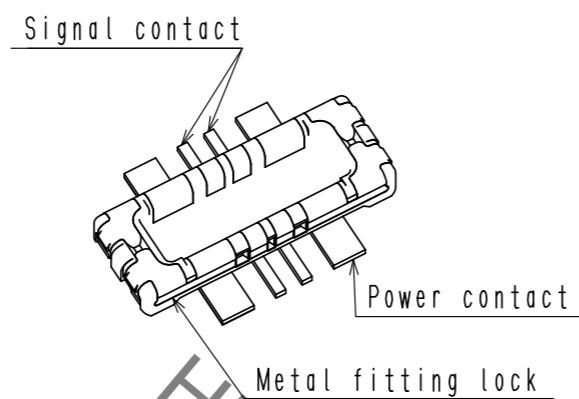
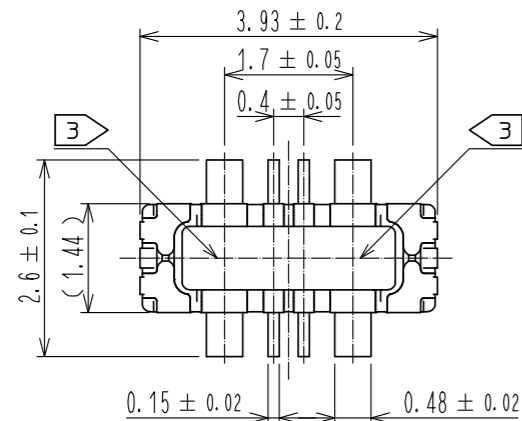

NOTE 1 . All lead co-planarity shall be 0.08mm MAX.  
 2 . Contact plating specifications  
 Contact area : Gold 0.05μm MIN  
 SMT lead : Gold 0.05μm MIN  
 Under plating : Nickel 1μm MIN  
 (Surface : Sealing)  
 3 . HRS mark and CAV No. are indicated in approx. position shown.

3	COPPER ALLOY	2	7	PS	CLEAR. REINFORCEMENT COLLAR				
2	COPPER ALLOY	2	6	PS	BLACK. PLASTIC REEL				
1	LCP	UL94 V-0. BLACK	5	POLYESTER	CLEAR. COVER TAPE				
			4	PS	CLEAR. EMBOSSED CARRIER TAPE				
NO.	MATERIAL	FINISH . REMARKS	NO.	MATERIAL	FINISH . REMARKS				
UNITS	mm	SCALE	10:1	COUNT	1	DESCRIPTION OF REVISIONS	DESIGNED	CHECKED	DATE
						DIS-H-00008831	TY.MORISHITA	TS.MIYAZAKI	20210531
APPROVED : MO. ISHIDA			20150226		DRAWING NO.		EDC-358234-51-05		
CHECKED : YH. MICHIDA			20150226		PART NO.		BM25-4P/2-V(51)		
DESIGNED : TR. YUNOKI			20150226		CODE NO.		CL0677-1201-2-51		
DRAWN : TR. YUNOKI			20150202						

Jan.1.2022 Copyright 2022 HIROSE ELECTRIC CO., LTD. All Rights Reserved.  
In case of consideration for using Automotive equipment / device which demand high reliability, kindly contact our sales window correspondents.

◆ Recommended PCB layout

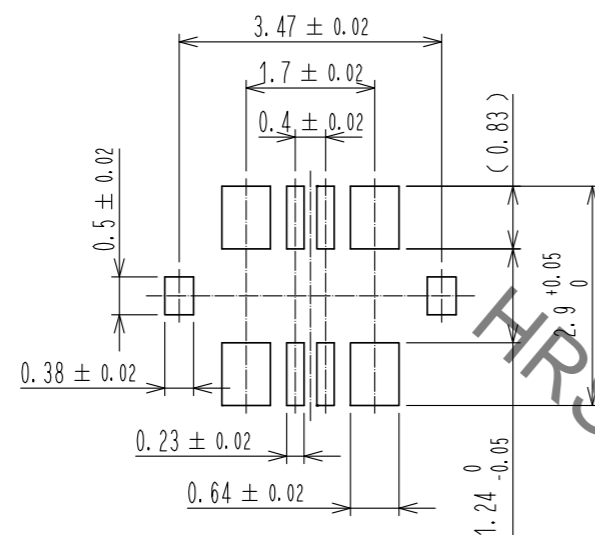

◆ Recommended metal mask dimensions  
Metal mask thickness : 100 μm

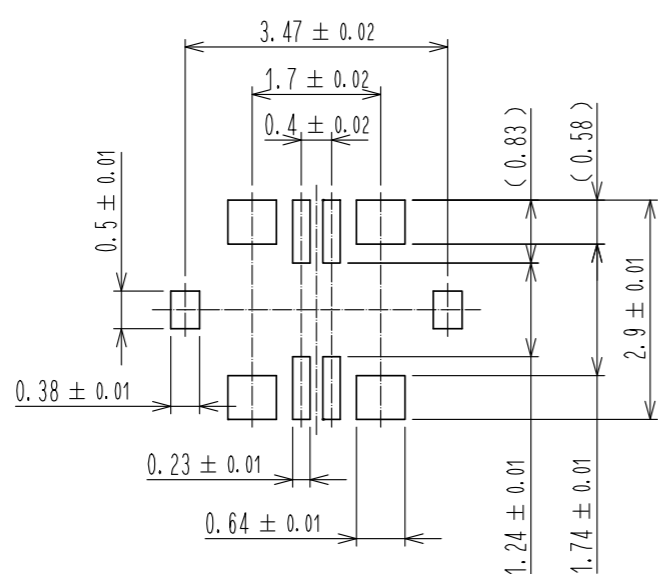

4 Recommended reflow temperature profile using lead-free solder paste.

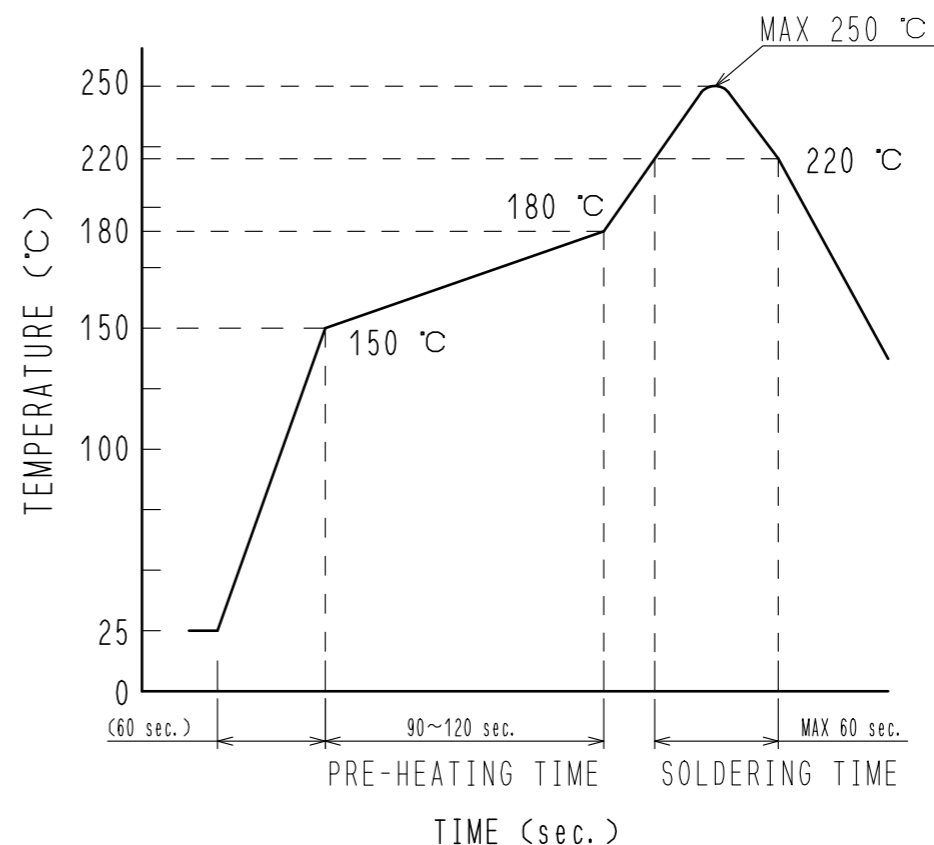

Reflow method: IR reflow  
 Number of reflow cycles: 2 cycles MAX.  
 1) Reflow time  
 Duration above 220°C: 60 sec MAX.  
 (Peak temperature: 250°C MAX)  
 2) Pre-heat time  
 Pre-heat temperature (MIN): 150°C  
 Pre-heat temperature (MAX): 180°C  
 Pre-heat time: 90-120 sec.

- 4 The temperatures mentioned above refer to the PCB surface temperature near the connector leads. The temperature profiles are based on the above conditions. In individual applications the actual temperature may vary, depending on solder paste type, volume/thickness and board size/thickness. Consult your solder paste and equipment manufacturer for specific recommendations.
- 5 Please contact us in case you will make different settings from our recommendation.

<b>HRS</b>	DRAWING NO.	EDC-358234-51-05
	PART NO.	BM25-4P/2-V(51)
	CODE NO.	CL0677-1201-2-51

Jan.1.2022 Copyright 2022 HIROSE ELECTRIC CO., LTD. All Rights Reserved.  
 In case of consideration for using Automotive equipment / device which demand high reliability, kindly contact our sales window correspondents.

Embossed carrier tape packaging (5:1)

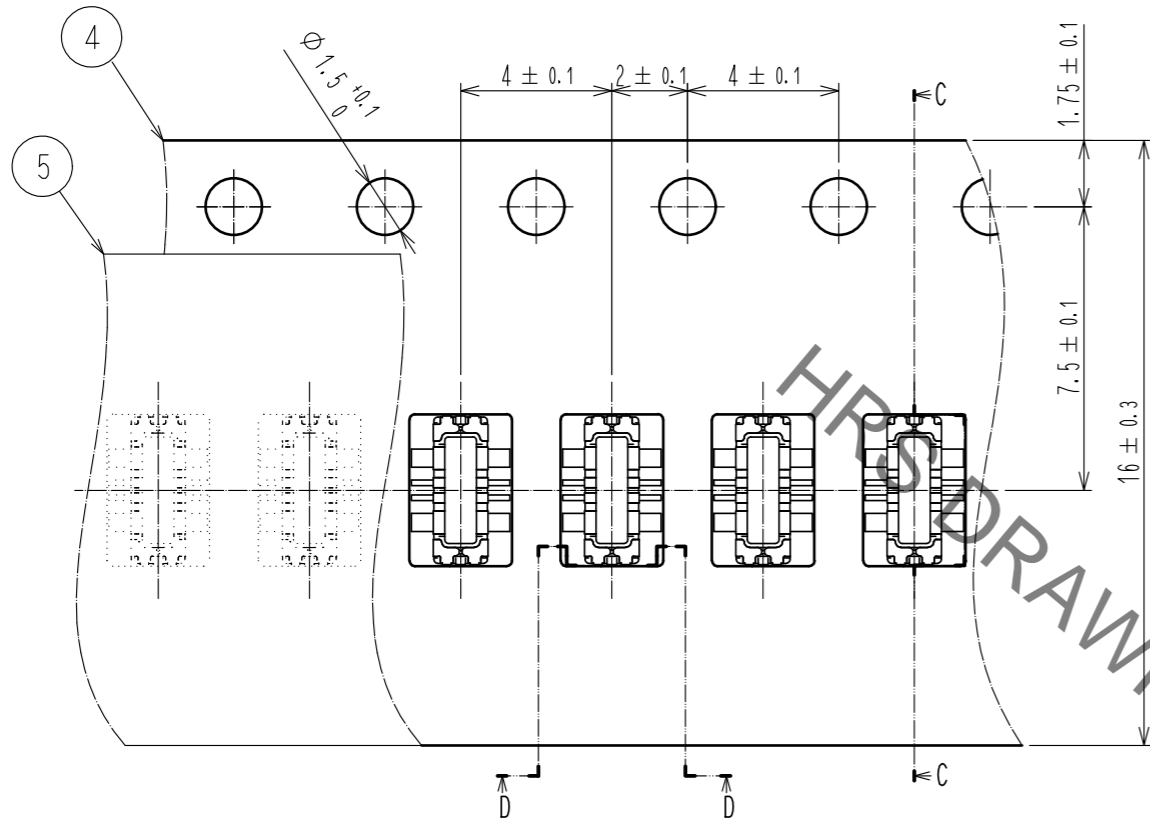

Direction of unreeling

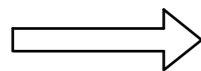

D-D (5:1)

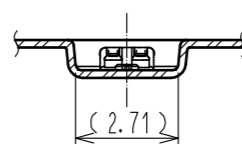

C-C (5:1)

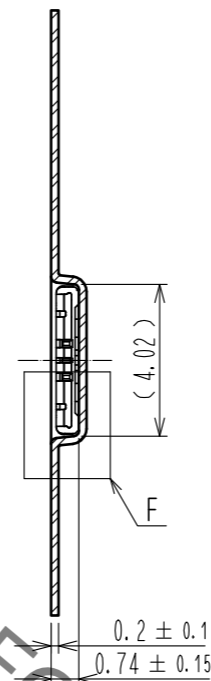

F (10:1)

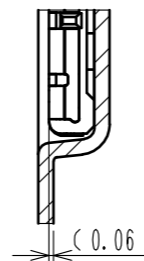

Style and dimension of reel (Free)

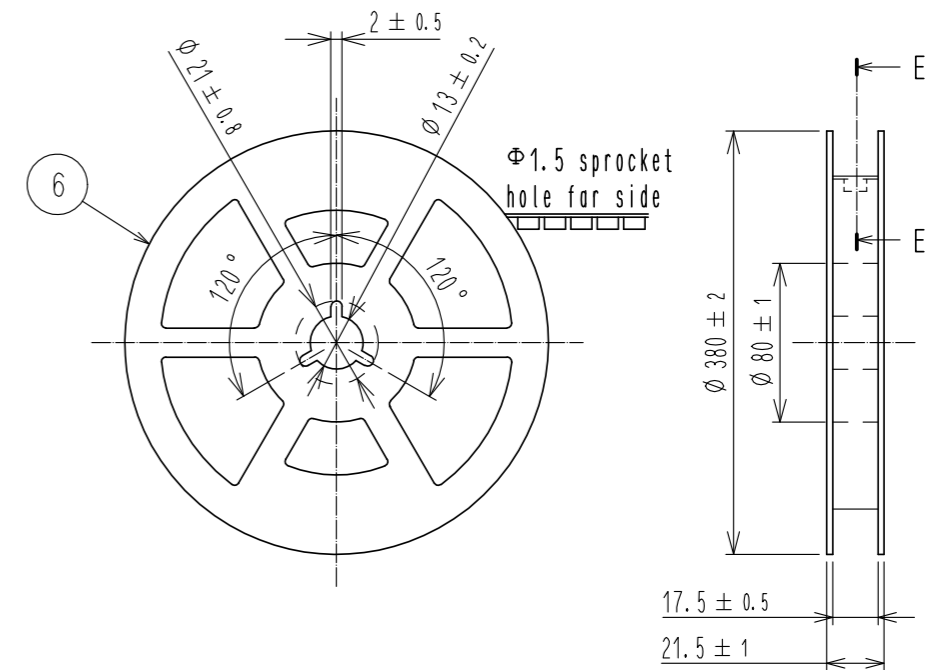

E-E (Free)

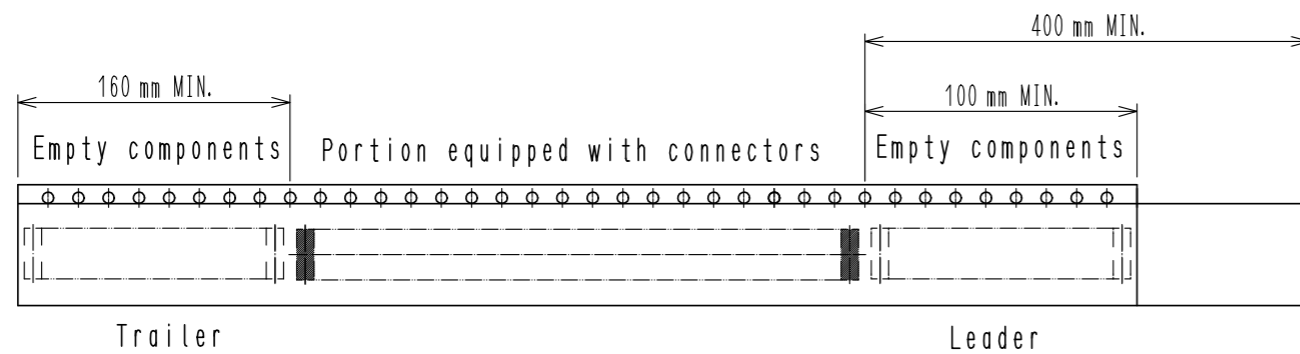
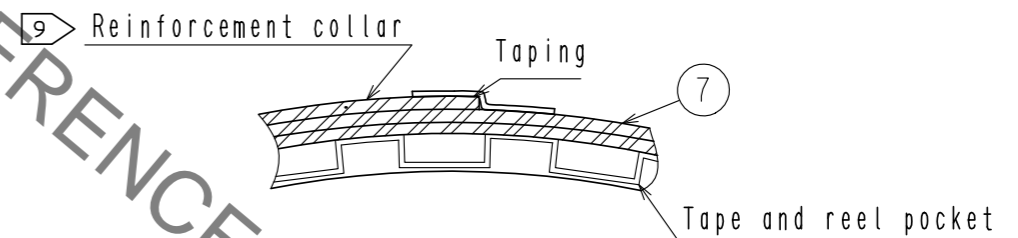

8 Taping (Free)

- 6 . Per reel 20,000 connectors.
- 7 . The dimensions in parentheses are for reference.
- 8 . Refer to JIS C 0806 and IEC60286-3  
(Packaging of components for automatic handling)
- 9 . Wrap a reinforcing collar made by polystyrene to the surface of emboss reel at the termination side in order to protect emboss carrier tape, top cover tape.

<b>HRS</b>	DRAWING NO.	EDC-358234-51-05
	PART NO.	BM25-4P/2-V(51)
	CODE NO.	CL0677-1201-2-51

Jan.1.2022 Copyright 2022 HIROSE ELECTRIC CO., LTD. All Rights Reserved.  
In case of consideration for using Automotive equipment / device which demand high reliability, kindly contact our sales window correspondents.

△ 10. PLEASE REFER TO THE PRODUCT GUIDELINE ETAD-H1018 FOR DETAIL OF CONNECTOR HANDLING.

### How to draw the FPC

BM25 series connector is intended to carry 10A electrical current for battery application. FPC may have less flexibility than usual, since the copper foil becomes wider and thicker to carry current of 10A.

Please design the FPC to have a flexibility to absorb the displacement\* of the connector caused by fixing PCB and battery.

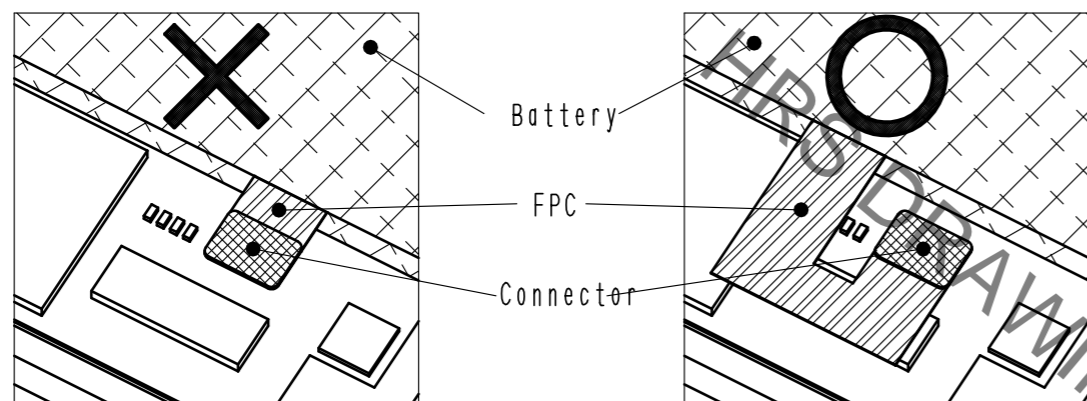

\*Possible problems caused by connector mating in incorrect positioning.  
Mating the connector in incorrect positioning could lose the function of the connector.

① Insulator could be broken.

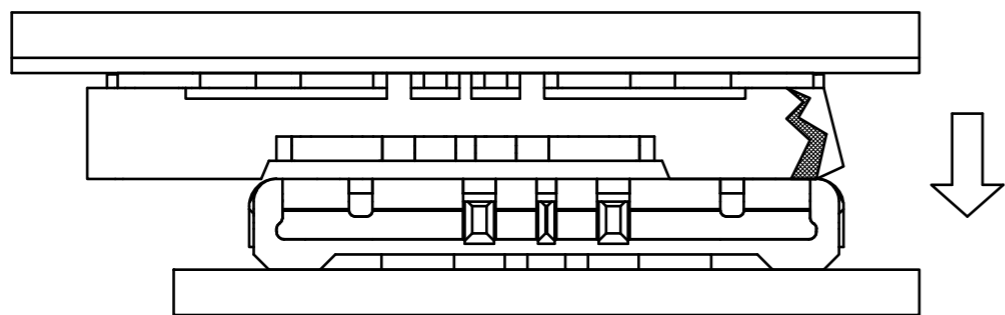

② It could apply excessive mechanical stress to single side of the contact.

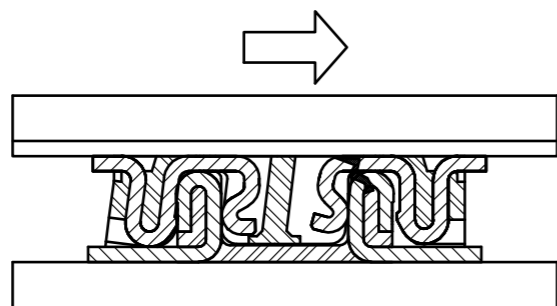

### How to draw the electrical circuit

As shown in the figure below, each power supply unit including the lock metal fitting has to be mounted on the same PCB circuit.

◆ Recommended electrical circuit layout

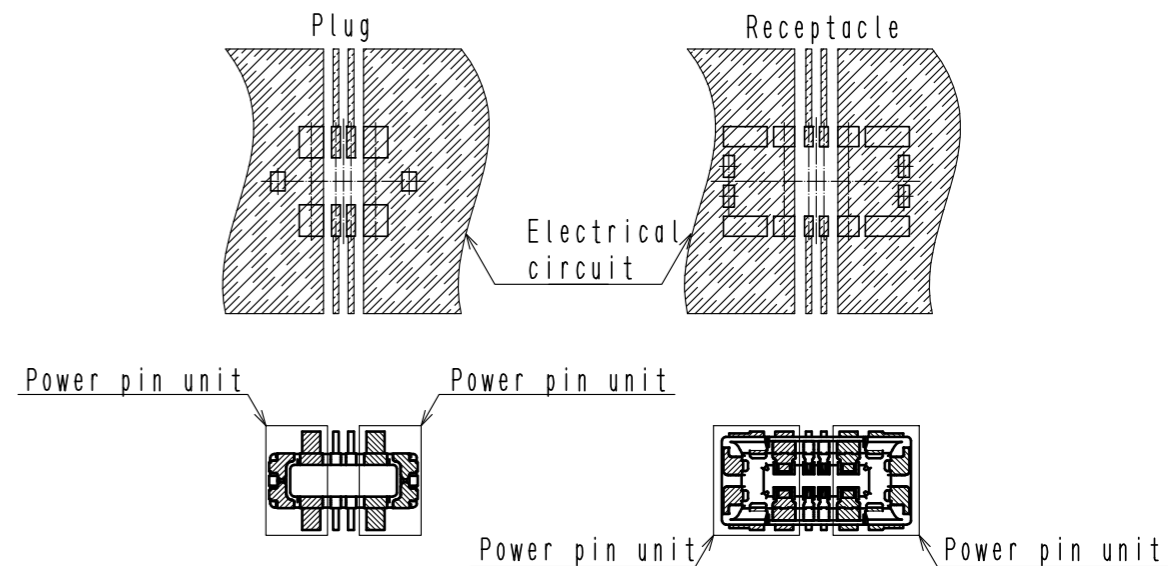

<b>HRS</b>	DRAWING NO.	EDC-358234-51-05	△ 4/5
	PART NO.	BM25-4P/2-V(51)	
	CODE NO.	CL0677-1201-2-51	

Jan.1.2022 Copyright 2022 HIROSE ELECTRIC CO., LTD. All Rights Reserved.  
In case of consideration for using Automotive equipment / device which demand high reliability, kindly contact our sales window correspondents.

### THE POSITION BETWEEN THE CONNECTOR AND PAD

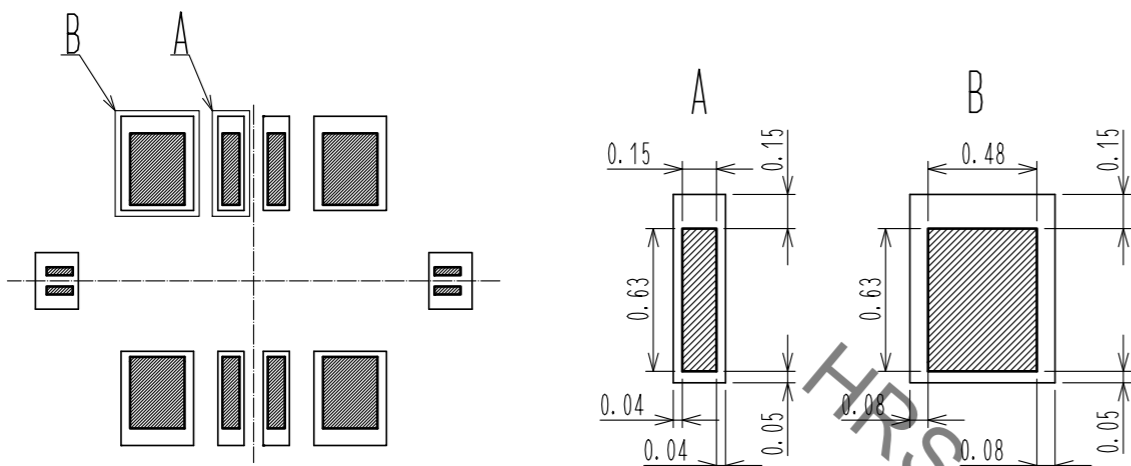

Connector lead on PAD layout  
 PAD layout

### MATING METHOD

PLEASE MATE THE CONNECTOR BY HAND.

#### MATING PROCEDURE

- (1) FIND THE ALIGNMENT AREA TO THE CONNECTOR IN THE APPROPRIATE MATING POSITION.  
 THIS CONNECTOR HAS AN ALIGNMENT CHAMBER(GUIDANCE RIBS) ON RECEPTACLE SIDE AND 'R' ON PLUG SIDE,  
 SO THAT THE CONNECTOR WILL BE SELF-ALIGNED.  
 WHEN THE CONNECTOR COMES TO THE APPROPRIATE POSITION, THE CONNECTOR GOES INTO THE ALIGNED POSITION.  
 WHEN ALIGNED, IT CAN BE FELT BY HAND.

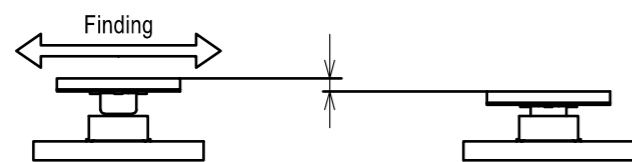
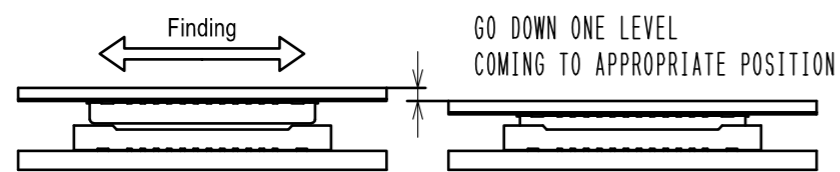

- (2) WHEN GUIDING, THE CONNECTORS ARE ALIGNED PARALLEL TO EACH OTHER, WITH LONGITUDINAL AND LATERAL MOVEMENTS RESTRICTED. MATE THEM PROPERLY BY APPLYING FORCE IN THIS CONDITION.



- (3) MAKE SURE THE CONNECTORS ARE MATED CORRECTLY. IF ONE SIDE IS FLOATING OR THE CONNECTORS ARE MATED IN ONE DIRECTION, UN-MATE THEM ONCE, AND THEN MATE THEM AGAIN, FOLLOWING THE PROCEDURES ABOVE FROM THE BEGINNING.

### UN-MATING METHOD

PLEASE UN-MATE THE CONNECTOR BY HAND

- (1) UN-MATE THE CONNECTORS PARALLEL TO EACH OTHER. HOWEVER, IF THE CONNECTORS HAVE HIGH PIN COUNTS OR THINNER FPC AND STIFFENER, IT BECOMES MORE DIFFICULT TO DO SO.

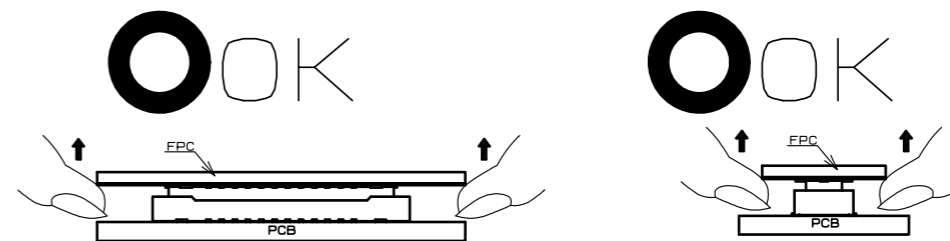

- (2) IF THE CONNECTOR CANNOT BE UN-MATED PARALLEL IT CAN BE REMOVED DIAGONALLY FROM THE PITCH DIRECTION. BE CAREFUL TO DO SO SINCE THIS ACTION APPLIES STRESS ON THE CONTACT.

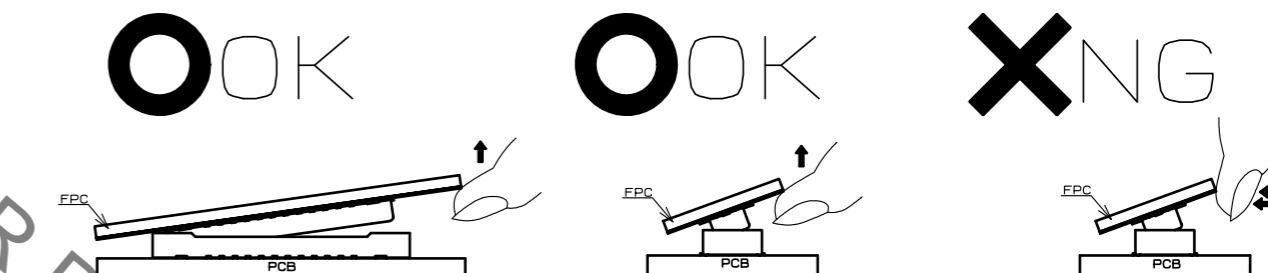

- (3) IF THE FPC IS NOT RIGID, THE CONNECTOR CAN BE BROKEN. PLEASE CHECK THE ACTION OF THE FPC TO BE USED REPEATEDLY AT THE TIME OF TRIAL PRODUCTION. BE CAREFUL TO UN-MATE THEM FROM THE PITCH DIRECTION, PULLING IT FROM THE CORNER CAN ALSO RISK TO PUTTING STRESS ON CONTACTS.

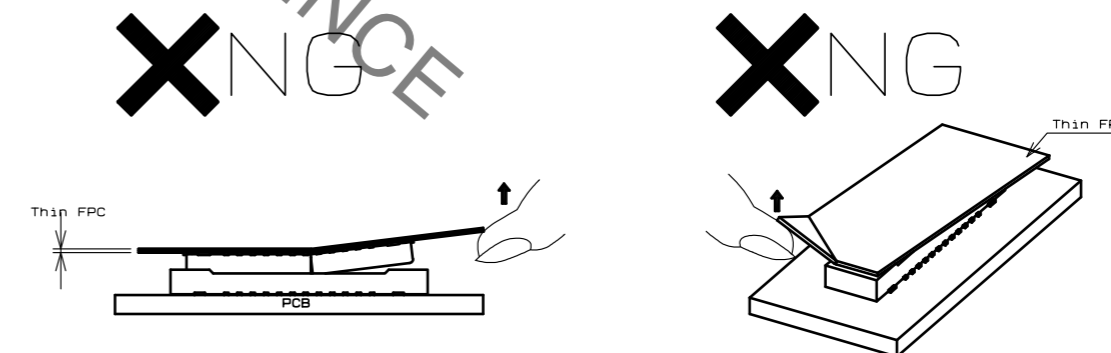

<b>HRS</b>	DRAWING NO.	EDC-358234-51-05
	PART NO.	BM25-4P/2-V(51)
	CODE NO.	CL0677-1201-2-51
		5/5

# Mouser Electronics

Authorized Distributor

Click to View Pricing, Inventory, Delivery & Lifecycle Information:

[Hirose Electric:](#)

[BM25-4P/2-V\(51\)](#)