

THIS DRAWING IS UNPUBLISHED. RELEASED FOR PUBLICATION
 © COPYRIGHT - By - ALL RIGHTS RESERVED.

LOC	DIST	REVISIONS					
FT	64	P	LTR	DESCRIPTION	DATE	DWN	APVD
		P		REVISED PER ECO-11-004835	11MAR11	RK	HMR

- 1 TIN PLATE PER ASTM B 545 .000254 [.000100] MIN THICK.
- 2 GOLD PLATE PER ASTM B 488, 0.00076 [.000030] MIN THICK OVER NICKEL PLATE PER QQ-N-290 0.00028 [.000011] MIN THICK ON CONTACT AREA.
- 3. RECOMMENDED HOLE SIZE, PLATED OR UNPLATED:
 MACHINE INSERTION: 1.04±0.05 [.041±.002]
 HAND INSERTION: 1.02 +0.10 / -0.00 [.040 +.004 / -.000]
- 4. APPLICATION TOOL PART NUMBER:
 MACHINE NO. 682127-2
 INSERTION HEAD NO. 682039-1
- 5 TO INSURE PROPER SPRING TENSION DO NOT EXCEED A 0.10 [.004] DIFFERENCE IN PIN DIA WHEN CHANGING TO A SMALLER PIN.
- 6. BOTTOM PLUG KNOCKOUT TOOL PART NUMBER 69729 WITH TIP PART NUMBER 69728.
- 7 MATERIAL:
 SPRING: BERYLLIUM COPPER PER ASTM B 194
 EYELET: COPPER PER ASTM B 152
- 8 OBSOLETE PARTS: OBSOLETE CIS STREAMLINING PER D.RENAUD/D.SINISI

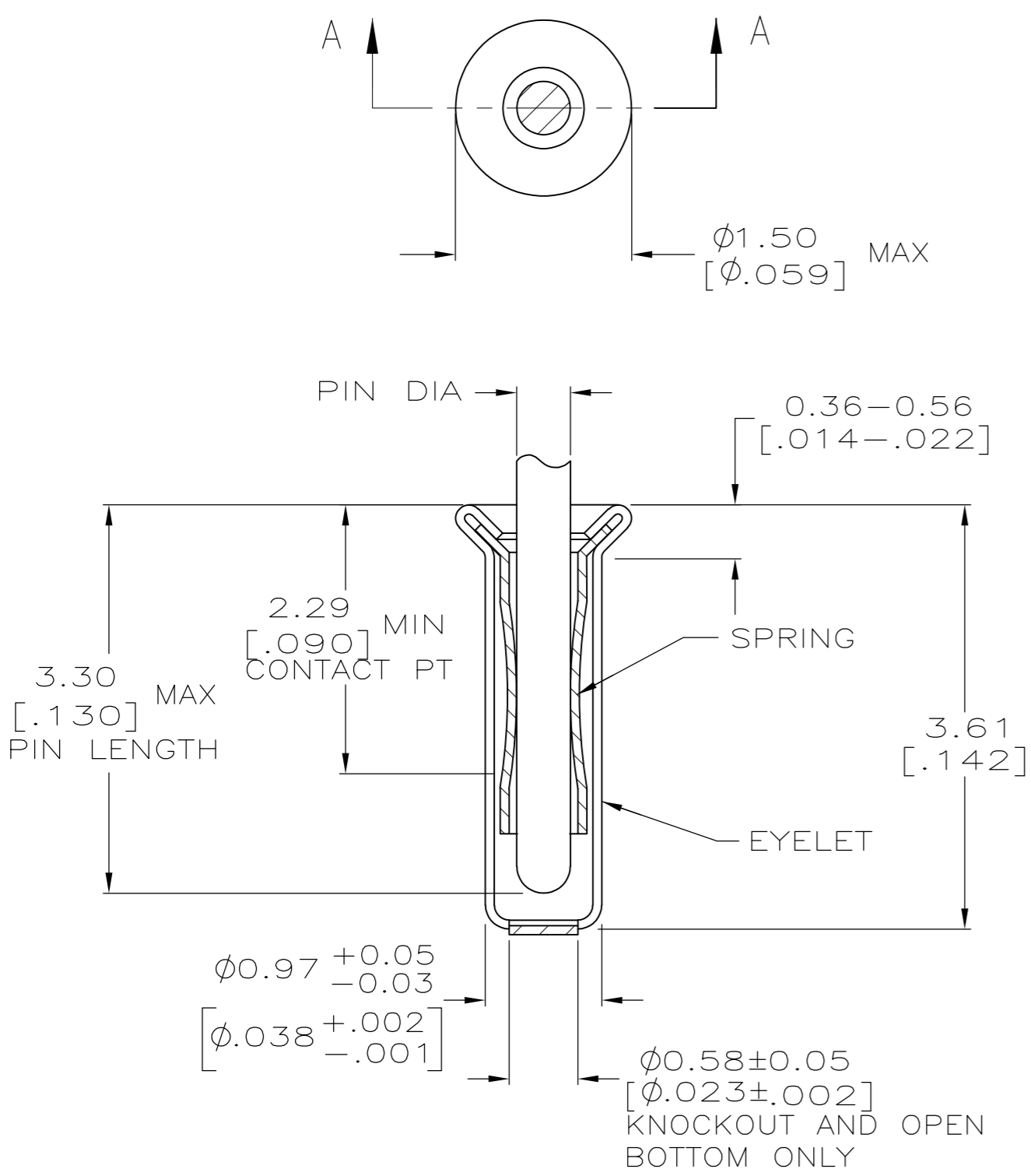

SECTION A-A

8 OBSOLETE	OPEN	0.46-0.51 [.018-.020]	TIN 1	GOLD 2	6-5330808-9
	CLOSED	0.33-0.51 [.013-.020]			6-5330808-5
SUPERSEDED BY 5-5330808-4	OPEN	0.25-0.33 [.010-.013]	TIN 1	GOLD 2	5-5330808-6
	KNOCKOUT	0.33-0.51 [.013-.020]			5-5330808-4
8 OBSOLETE	CLOSED	0.25-0.33 [.010-.013]	TIN 1	GOLD 2	5-5330808-3
	OPEN	0.33-0.51 [.013-.020]			5-5330808-0
8 OBSOLETE	OPEN	0.33-0.51 [.013-.020]	TIN 1	GOLD 2	4-5330808-7
	CLOSED	0.33-0.51 [.013-.020]			2-5330808-7
BOTTOM TYPE	RECOMMENDED PIN DIA	5	EYELET	SPRING	PART NO

THIS DRAWING IS A CONTROLLED DOCUMENT.		DWN A. FERNANDEZ-DOCK5 20APR2005				
DIMENSIONS: INCHES		CHK J. HAVENER 20APR2005				
TOLERANCES UNLESS OTHERWISE SPECIFIED:		APVD J. HAVENER 20APR2005	NAME MINIATURE SPRING SOCKET ASSEMBLY SERIES 1			
0 PLC ± - 1 PLC ± - 2 PLC ± - 3 PLC ± 0.20 [.008] 4 PLC ± - ANGLES ± -		PRODUCT SPEC 108-14008	SIZE A2	CAGE CODE 00779	DRAWING NO C-5330808	RESTRICTED TO -
MATERIAL 1		FINISH SEE TABLE	WEIGHT -	SCALE 20:1	SHEET 1 of 1	REV P